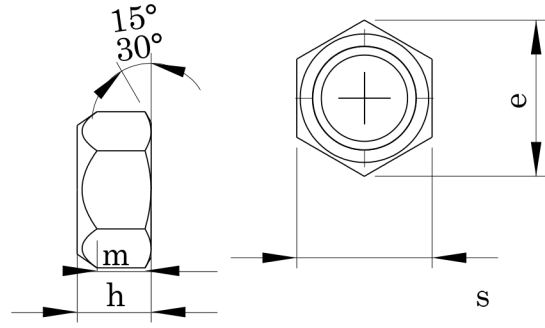

DIN 980/V ISO 7042**SIKMALI ALTI KÖŞE SOMUN****PREVAILING TORQUE TYPE HEXAGON NUT , ALL METAL****SICHERUNGSMUTTER (GANZMETALLMUTTER)****Technical Informations / Teknik Bilgiler**

Thread size / Anma çapı (d)		M6	M8	M10	M12	M14	M16	M18	M20	
Pitch / Diş adımı	P ₁		M8x1,00	M10x1,00	M12x1,50	M14x1,50	M16x1,50	M18x2,00	M20x1,50	
	P ₂			M10x1,25	M12x1,25			M18x1,50	M20x2,00	
	P ₃	1,00	1,25	1,50	1,75	2,00	2,00	2,50	2,50	
Flange dia / Flanş çapı	da	min.	6,00	8,00	10,00	12,00	14,00	16,00	18,00	20,00
		max.	6,75	8,75	10,80	13,00	15,10	17,30	19,50	21,60
Diagonal / Köşegen	dw	min.	8,90	11,60	15,60	17,40	20,50	22,50	24,90	27,70
	e	min.	11,05	14,38	18,90	21,10	24,49	26,75	29,56	32,95
Height / Yükseklik	h	min.	5,70	7,50	9,00	11,00	12,00	14,00	16,00	18,00
		max.	6,00	8,00	10,00	12,00	14,00	16,00	18,00	20,00
Head width / Anahtar ağızı s	m		3,30	4,40	5,50	6,60	7,70	8,80	9,90	11,00
		min.	9,78	12,73	16,73	18,67	21,67	23,67	26,16	29,16
Weight / Ağırlık	s	min.	10,00	13,00	17,00	19,00	22,00	24,00	27,00	30,00
		max.	2,90	6,00	11,70	16,60	21,00	37,80	54,4	69,80
	gr/p									

Values are given in millimeters. / Değerler milimetre olarak verilmiştir.